

# INSTALL Manual

## BRIDGEPOINT SYSTEMS



© Bridgepoint Systems  
542 W Confluence Ave.  
Salt Lake City, UT 84123  
Phone 801-261-1282 • Fax 801-268-3856

Revised: 02/19/07

# Table of Contents

Introduction	3
General Information	4
Installation	5

## SECTION 1

Propane Safety	10
Propane Vaporization Rates	12
Heater Operation Safety	13



## SECTION 2

Warranty	16
----------	----

# Introduction

This manual is a guide for safe installation, operation and maintenance of this unit.

**Read and understand this manual completely before installing or operating this unit.**

This manual should be kept in your service department for future reference.

Any questions pertaining to the operating or servicing of this unit should be directed to your nearest Bridgepoint Systems distributor.

**Local regulations regarding the storage, transportation and use of propane may restrict or prohibit the operation of the TES Thermal Energy System in some areas. Check with your local fire safety authorities before operating this equipment.**

**Warning:** Improper installation, operation, adjustment, alteration, service or maintenance can cause property damage, personal injury or loss of life. Installation and service must be performed by a qualified installer, service agency or gas provider. Bridgepoint Systems is in no way responsible and is excluded from liability in respect to any loss or damage which may arise due to improper installation, operation or maintenance.

This manual is written specifically for the TES Thermal Energy System units manufactured by:

Bridgepoint Systems  
542 W Confluence Ave.  
Salt Lake City, UT 84123  
801-261-1282

Information in this manual is subject to change without notice and does not represent a commitment on the part of Bridgepoint Systems.

# General Information

## TES HEATER ASSEMBLY

### 200,000 Btu Propane/LP Gas Boiler – Outdoor Model

Stainless steel covers and Stainless Steel base with powder coated steel reinforcements and mounting feet.

<b>Height:</b>	36-3/8" (Without wheels & vent cap) 45-7/8" (With wheels & without vent cap) 47-3/8" (Without wheels & with vent cap) 56-7/8" (With wheels & vent cap)
<b>Length:</b>	47-1/2" (Without handle) 50" (With handle)
<b>Width:</b>	35-1/8" at widest point (Outdoor Hood) 25-5/8" at base
<b>Weight:</b>	450 lbs.
<b>Pump:</b>	All stainless steel liquid end construction – Close coupled end suction single stage centrifugal pump with high temp seal. 3/4HP – 3450 rpm - 75 psi Maximum liquid temperature - 250°F (120°C)

## TEX THERMAL EXCHANGER

<b>Height:</b>	19-7/8"
<b>Length:</b>	24"
<b>Width:</b>	20-5/8"
<b>Weight:</b>	50 lbs.

## Standard Equipment

### TES Heater Assembly

1 – 10' Propane Hose with Regulator

4 - TEX Thermal Exchangers

2 - TES Hose 3/4" x 50' Red Insulated w/ 3/4" Quick connects

2 - TES Hose 3/4" x 50' Blue Insulated w/ 3/4" Quick connects

4 - TEX Hose 5/8" x 50' Red Insulated w/1/2" Quick connects

4 - TEX Hose 5/8" x 50' Blue Insulated w/1/2" Quick connects

2 - Inlet Solution Tee - 3/4" Female QC to (2) 1/2" Male QC's

2 - Outlet Solution Tee - 3/4" Male QC to (2) 1/2" Female QC's

4 - QD Wraps – Large

8 - QD Wraps – Medium

## Additional / Optional Equipment

Wheel Kit:	AT52
50' Power Cord:	AX33
Shock Buster GFCI:	AX126
TES Hose 3/4" x 50' Red Insulated w/ 3/4" Quick connects:	AH108
TES Hose 3/4" x 50' Blue Insulated w/ 3/4" Quick connects:	AH110
TES Hose 3/4" x 25' Red Insulated w/ 3/4" Quick connects:	AH116
TES Hose 3/4" x 25' Blue Insulated w/ 3/4" Quick connects:	AH118
TEX Hose 5/8" x 50' Red Insulated w/1/2" Quick connects:	AH112
TEX Hose 5/8" x 50' Blue Insulated w/1/2" Quick connects:	AH114
Inlet Solution Tee - 3/4" Female QC to (2) 1/2" Male QC's:	AH104
Outlet Solution Tee - 3/4" Male QC to (2) 1/2" Female QC's:	AH106
TEX Thermal Exchangers:	MB212
TES Thermal Fluid – Gallon:	CR01GL
QD Wraps – Large:	AH10L
QD Wraps – Medium:	AH10M
Adapter for Dual Propane Tanks:	AT68
Adapter for Triple Propane Tanks:	AT69
Trailer Rack for 3 Propane Tanks:	AT70
TES Trailer Mount Support Frame:	AT78
Trailer Fan Kit:	AT76
Shelf for 4 Air Movers:	AT72
Shelf for 6 Air Movers:	AT74
Trailer Vent Cap (J-cap):	NM4330
Floor Anchor	NM4328
Trailer Propane Install Kit:	AT90
Trailer Exhaust Kit:	AT92
Trailer Mounting Kit:	AT96

### **High Altitude Burner Jets:**

The efficient operation of this heater depends on the proper fuel air mixture in the combustion chamber. The amount of fuel required for proper combustion will vary with changes in altitude. With less oxygen available for combustion at higher altitudes, less fuel can be burned and the Btu input rating of the heater is reduced by 4% for each 1000 feet above sea level. The standard TES unit is designed for operation at elevations from sea level to 2000 feet. Use of the TES unit at altitudes above 2000 feet will require replacing the burner jets with smaller jets to reduce the gas flow to match the lower oxygen levels. If the jets are not changed, the excess fuel will result in poor combustion and black soot build up that will impair the heater's performance or damage the heater. Burner replacement should only be performed by trained technicians.

The following Burner Jets are available for operation of your TES unit at higher altitudes:

<b>2000 – 4000 Feet:</b>	<b>NM4294</b>	<b>(4 required)</b>
<b>4000 – 6000 Feet:</b>	<b>NM4296</b>	<b>(4 required)</b>
<b>6000 – 8000 Feet:</b>	<b>NM4298</b>	<b>(4 required)</b>

Burner jets are installed at the factory for operation at the altitude of your location at the time your unit was shipped from the factory. Check the rating plate to assure jets are matched to your altitude.

## Installation & Transportation

The TES unit must be properly installed in a trailer or secured properly during transportation to the job sites. **Installation must be performed by an authorized service center.** Failure to do so will void the warranty and may result in property damage, personal injury or death. Bridgepoint Systems is in no way responsible and is excluded from liability in respect to any loss or damage which may arise due to improper installation, operation or maintenance. When selecting a vehicle or trailer to transport or mount the TES unit, be sure the trailer or vehicle can handle the combined weight of the TES unit, TEX units, hoses, propane tanks and accessories. The approximate combined weight of the standard package TES Thermal Energy System with three 100# propane tanks is 1600 lbs.

**Trailer Use Mounting:** Secure the TES unit to the floor of the trailer with the four mounting feet provided with the base. Each foot is secured to the TES unit base with a snap pin. The mounting foot secured to the floor with hardware as shown below. At least two bolts through each mounting foot with back-up plates under the floor. If possible place one bolt from each mounting foot through a steel support beam under floor. Position the TES unit to balance the load over the axle or axles. Proper weight distribution is important to balance the trailer and keep the tongue weight within the specifications for the trailer and towing vehicle.

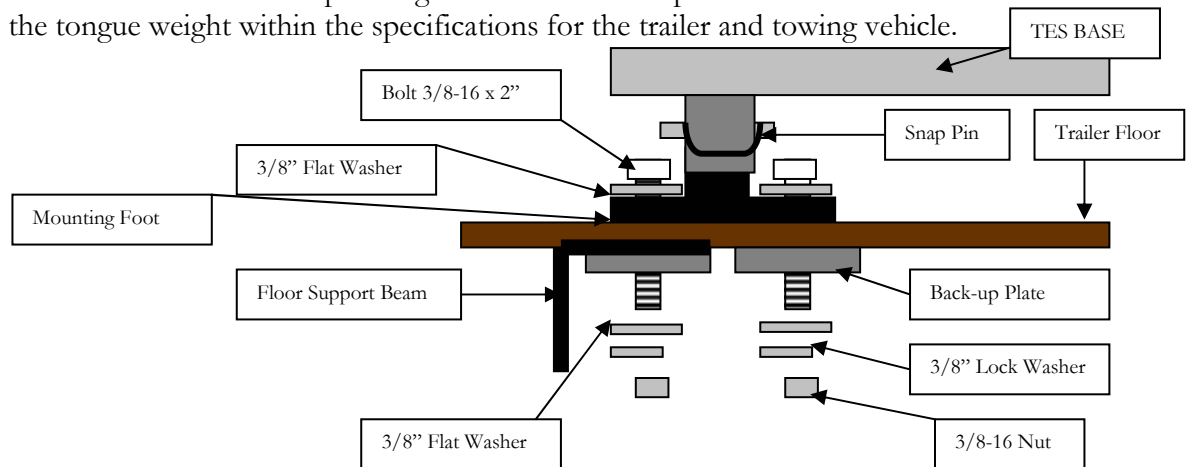

- If the TES unit is to be installed for use in a closed trailer, there must be at least 6" of space between the heater and the trailer wall. An exhaust stack must be installed to vent the burner exhaust through the roof of the trailer. There must be sufficient ventilation to exhaust the heat and supply adequate combustion air to the burner.
- A 7" diameter exhaust stack with vent cap is required. Use a "J" cap or other wind resistant style vent cap. Never install an exhaust pipe of a diameter different than that of the heater draft hood. 6" of clearance is required between the exhaust stack and any combustible materials. Use the shortest, straightest exhaust system possible.
- Two roof vents must be installed to exhaust the heat from the trailer and allow proper flow of combustion air. The roof vents must have a total minimum free area of 100sq. in. When calculating the vent area, consideration must be given to the blockage effects of louvers, grills and screens. The installation of two roof vents should easily provide sufficient vent air space when allowing for blockage. **Power vents should not be used. The heater should not be subjected to negative air pressure.** Negative air pressure can affect the burner flame and exhaust flow.

- Openings for the combustion air supply must have a total minimum free area of 100 sq. in. When calculating the vent area, consideration must be given to the blockage effects of louvers, grills and screens. The openings must be within 12” but not less than 3” from the floor of the trailer. A power vent fan may be used to bring in air. The free air space of the hose access door can be used as part of the total vent space. The blockage of the hoses must be considered when calculating the free space of the hose access door. The hoses may reduce the total free area to a total less than the required 100 sq. in. and require the addition of a second vent.
- Ambient air temperature above 130°F inside the trailer may adversely affect the operation of the pump and heater. When the outside air temperature is above 60°F, a power vent fan must be used to bring in cooler air, to provide adequate cooling for TES operation. Power exhaust fans should not be used. The fan should have at least 600 cfm of air movement. Locate fan within 12” but not less than 3” from the floor of the trailer.

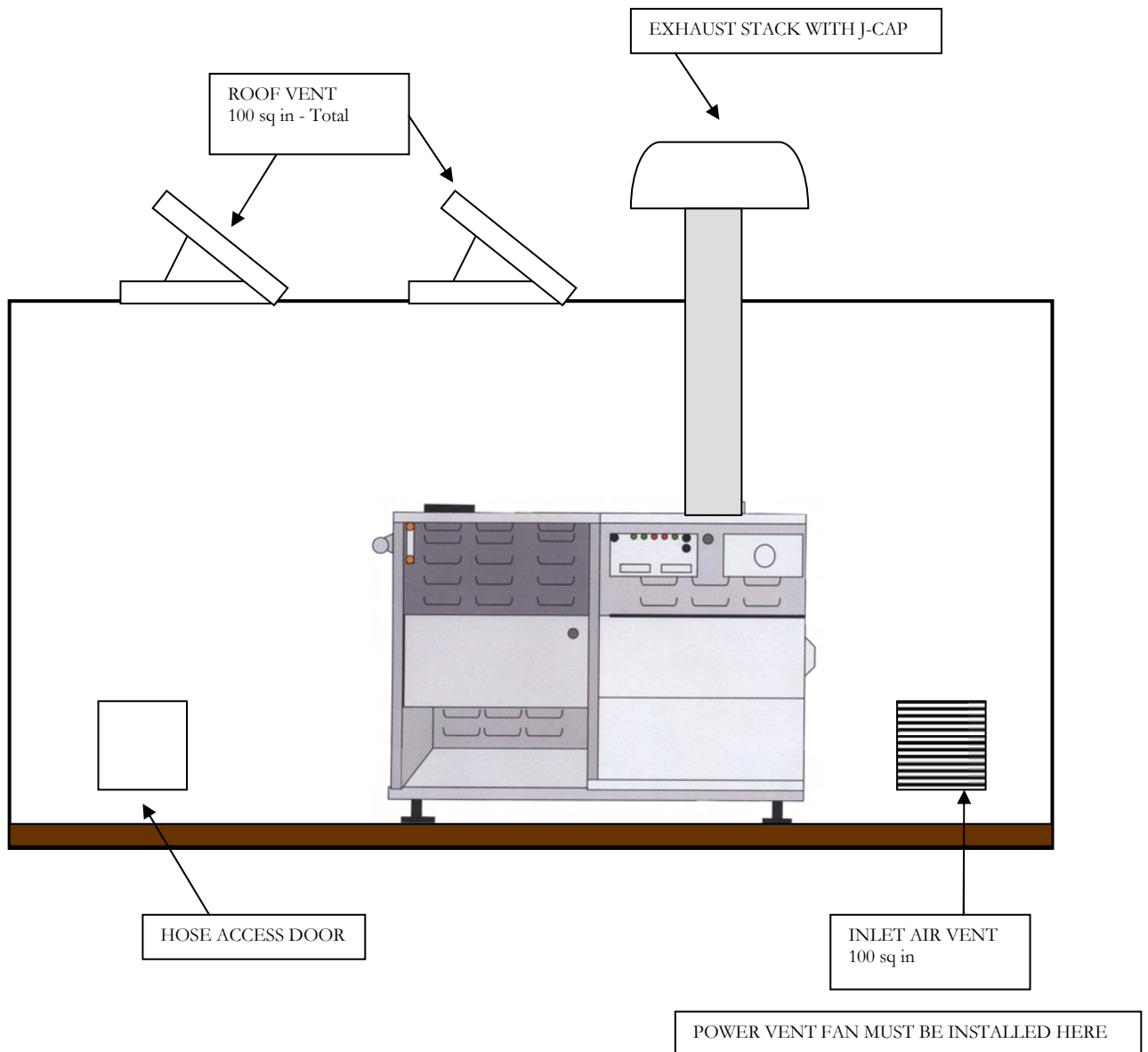

**Portable Use Mounting:** The TES unit must be securely mounted to the floor of the van or trailer. The anchors and tie down system must be rated to hold more than the 450 lb. weight of the TES unit. The anchors must be securely attached to the vehicle floor and floor support beams to prevent the TES Heater from coming loose in a collision or quick stop situation. Align anchors and tie downs to provide adequate restraint to prevent forward and back as well as side to side movement during transportation. For the most secure mounting, place a Mounting Frame under the TES unit before tightening tie down turnbuckles. Tighten turnbuckles until TES base contacts mounting frame. Inspect the turnbuckles, feet and anchors after each use and replace if damaged. A weakened tie down component may allow the machine to break loose. See illustrations below for an example of one tie down system.

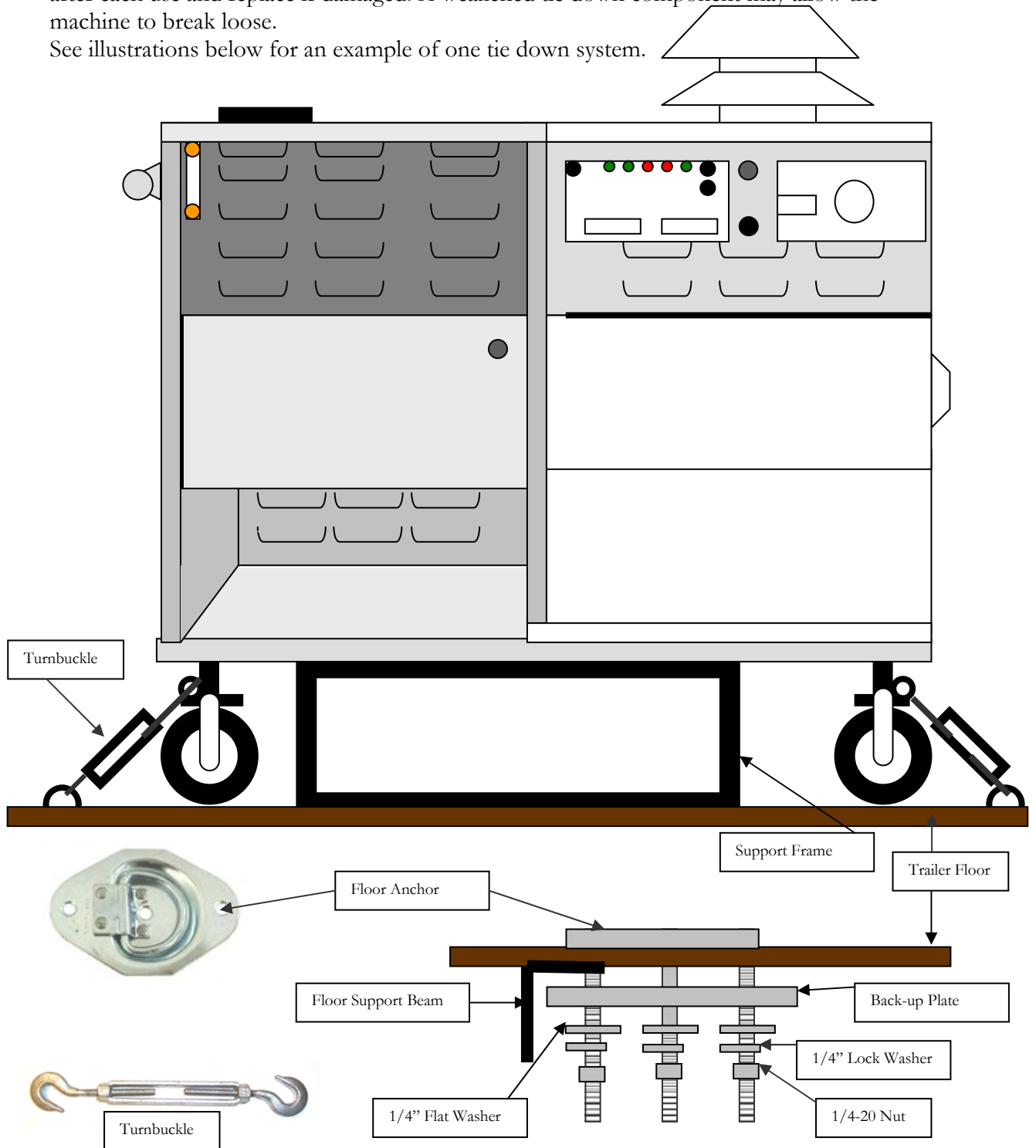

**Propane Tank Mounting:** When the TES unit is mounted in the trailer the propane tanks cannot be used inside the trailer. The propane tanks must be secured properly for both transportation and use – in accordance with local, state and federal regulations. A rack for the propane tanks can be installed on the trailer tongue. The tanks can be removed from the rack for portable use or connected to the heater for in trailer use.

Read the section in this manual on propane safety. (Pages 10 & 11)

**Check with your local propane supplier for local regulations regarding the use, storage and transportation of propane. Bridgepoint Systems is in no way responsible and is excluded from liability in respect to any loss or damage which may arise due to improper installation, use, storage or transportation of propane and propane tanks.**

- A full 100# propane tank weighs approximately 150 lbs.
- Tongue mounting of propane tanks will greatly increase tongue weight. Balance trailer load to keep total tongue weight within limits of towing vehicle.
- Install a gas shutoff valve between the propane tanks and TES unit in trailer.
- Propane regulator must be installed outside of trailer. Install regulator with vent down or under protective cover. A second regulator can be purchased for more convenient use with the TES unit outside of the trailer.
- Use bulkhead fittings to make hose connections through floors and walls.
- Route and secure hoses to protect them from wear or damage.
- Close propane tank valves during transportation and storage.
- Close gas valve during transportation and storage.
- Turn open side of valve guard toward trailer during transportation.
- Make sure tanks are secured and will not move during transportation.
- Check for leaks before turning on heater every time TES unit is used.
- Examine hoses and fittings before and after each use. Repair or replace hoses and fittings as needed to assure safe operation before using TES unit.
- Examine tanks and replace if damaged. Do not use tanks if heavily dented, bulging or corroded.



## Propane Safety

*Propane is highly flammable, always contained under pressure and the liquid can freeze skin. It is important to understand the safety rules for propane storage and use.*

- Propane or LP-gas is a true gas compressed into liquid form for easy transportation and storage. While stored in a compressed liquid form, most appliances such as the TES Heater use propane vapor only. Propane tanks designed for vapor service must be transported, stored and used in the proper position. Do not transport, store or use vertical cylinders in a horizontal position. Never use a horizontal tank on its improper side. **Failure to follow these guidelines may allow liquid propane to get into the heating system, create unsafe conditions and damage the heater.**
- Do not fill propane tanks to more than 80% of capacity.
- Secure the tanks during transportation, storage and use to prevent falling and rolling.
- Do not use damaged or rusted tanks. Tanks that show excessive denting, bulging, gouging or corrosion must be removed from service. Do not attempt to repair propane tanks, valves or regulators.
- Do not operate the TES Heater with a propane tank inside a closed trailer.
- Keep a dry chemical fire extinguisher with a B:C rating within 50 feet of tanks during use or storage.
- Laws concerning the proper storage of propane tanks may vary in different jurisdictions. Consult your local fire protection authorities.
- Do not use a wrench to close tank valve. These valves are designed to be closed leak tight by hand. If a wrench is needed to stop leaking, remove the tank from service immediately and have the valve replaced by a qualified professional.
- When connecting propane regulator and hose to the tank valve, turn the fitting nut counter-clockwise to tighten. Draw the fitting snug with the proper wrench. Do not over tighten. No thread sealant is needed.
- Do not smoke in the area of the propane tanks or heater.
- Do not operate the TES Heater indoors.

- Before operating the TES Heater check around the heater for the smell of propane. Propane gas is heavier than air and can collect in low areas. Check around base of the heater for the smell of propane.
- A distinctive odor is added to propane. However propane leaks cannot always be detected by smell. Some people do not have a good sense of smell or certain conditions may affect your sense of smell. In rare cases propane gas can lose its added odor. This is called “odor fade”. It may occur when air, water or rust accumulates in a propane tank. The smell of escaping gas can also be absorbed by water, some soils or other materials. If you think your propane gas has lost its odor contact your propane dealer to check it out.
- Electronic gas detectors are commercially available and may provide an additional means of warning about the presence of propane.
- Use soapy water to check connection for propane leaks.
- Never use a match or flame to check for propane leaks.
- If you suspect a leak:
  - Do not attempt to start heater.
  - Close the valves on the propane tanks.
  - Do not touch any electrical cords, plugs or switches in the area of the suspected leak.
  - Do not operate any phone or electrical device in the area of the suspected leak.
  - Leave the area until the propane smell dissipates. If a large amount of propane is being released or the gas cannot be dissipated, leave the area and contact the fire department.
  - Have the propane system checked and repaired before using the heater.
- Absolutely no alterations or modifications should be made to your propane system. The slightest modification or alteration to your propane system by untrained personnel may cause a potentially dangerous or life-threatening situation.
- Do not operate this heater if any part has been under water. Have a qualified propane system service technician inspect the system and replace any part of the control system that has been under water.
- Have the propane system checked annually by a qualified propane system service technician
- To reduce the risk of property damage or injury, repairs to propane systems should only be performed by experienced technicians. Contact your nearest service center for assistance.

**Check with your local propane supplier for local regulations regarding the use, storage and transportation of propane.**

# PROPANE VAPORIZATION AND TES OPERATION

The ambient air temperature and the level of propane in the tank both affect the vaporization rate of the propane. The decrease in vaporization in colder weather may prevent the TES unit from operating properly on 1-2 tanks and may require 3-4 tanks for proper operation in cold weather.

- At 70°F a full 100# propane tank has a maximum draw of 300,000 BTU per hour. At the same temperature a 1/2 full 100# tank has a maximum draw of 167,000 BTU per hour.
- At 0°F a full 100# tank has a maximum draw of 113,000 BTU per hour. At the same temperature a 1/2 full 100# tank has a maximum draw of 64,000 BTU per hour.

The following chart shows the number of hours the TES boiler can run in at full burn at different temperatures. This is not necessarily the maximum operation time for the TES unit. The amount of time the boiler is off or in low fire operation will increase the total use time. Higher ambient temperatures, higher structure interior temperatures as well as a lower number of TEX Thermal exchangers used and even setting the air movers on lower settings for less air flow, will all reduce the full burn time to allow much longer run times in practical applications.

To determine how many propane tanks to use, how much continuous full burn run time can be expected from a TES unit and when tanks should be re-filled or replaced to maintain the proper propane flow for the TES unit, use the following chart:

Number of 100# Propane Cylinders	Hours of TES Unit Operation at continuous full burn at various temperatures. 0-1999 Ft Operation				
	0°F	20°F	40°F	60°F	70°F
1	0	0	2.16 hrs	3.24 hrs	4.00 hrs
2	2.16 hrs	9.73 hrs	13.19 hrs	15.13 hrs	16.86 hrs
3	15.24 hrs	22.38 hrs	25.94 hrs	28.86 hrs	32.43 hrs
4	27.24 hrs	34.59 hrs	43.24 hrs	43.24 hrs	43.24 hrs

Number of 100# Propane Cylinders	Hours of TES Unit Operation at continuous full burn at various temperatures. 2000-3999 Ft Operation				
	0°F	20°F	40°F	60°F	70°F
1	0	0	2.49 hrs	3.74 hrs	4.61 hrs
2	2.49 hrs	11.21 hrs	15.20 hrs	17.44 hrs	19.44 hrs
3	17.57 hrs	25.79 hrs	29.90 hrs	33.27 hrs	37.38 hrs
4	31.40 hrs	39.87 hrs	49.84 hrs	49.84 hrs	49.84 hrs

Number of 100# Propane Cylinders	Hours of TES Unit Operation at continuous full burn at various temperatures. 4000-5999 Ft Operation				
	0°F	20°F	40°F	60°F	70°F
1	0	0	2.71 hrs	4.07 hrs	5.02 hrs
2	2.71 hrs	12.20 hrs	16.54 hrs	18.98 hrs	21.15 hrs
3	19.12 hrs	28.07 hrs	32.54 hrs	36.21 hrs	40.68 hrs
4	34.17 hrs	43.39 hrs	54.24 hrs	54.24 hrs	54.24 hrs

Number of 100# Propane Cylinders	Hours of TES Unit Operation at continuous full burn at various temperatures. 6000-7999 Ft Operation				
	0°F	20°F	40°F	60°F	70°F
1	0	0	2.96 hrs	4.44 hrs	5.79 hrs
2	2.96 hrs	13.31 hrs	18.04 hrs	20.71 hrs	29.58 hrs
3	20.85 hrs	30.62 hrs	35.50 hrs	39.49 hrs	44.37 hrs
4	37.27 hrs	47.33 hrs	59.16 hrs	59.16 hrs	59.16 hrs



- Do Not Use



- Not Recommended

- The heater may continue to burn longer than these times indicate, but the heat input from the propane available to heat the fluid will be less than the 200,000 BTU maximum.

## Heater Operation Safety

*This heater is designed for outdoor use. It is not to be operated indoors.*

- The TES unit was designed for outdoor use and **is not** to be used indoors. The TES unit can be operated from an enclosed trailer with the proper installation and venting for combustion air and exhaust. Do not place TES unit where exhaust fumes can enter buildings. The TES unit must be at least 10 ft. away from any door, window or gravity air inlet into any building and at least 3 ft. from any overhang.
- **The TES unit must level during operation.** Using the heater in a sloped position will change the position of the burner flame in relation to the burner tubes and heat exchanger. This can result in property damage, personal injury or loss of life.
- Colder temperatures will decrease the vaporization rate of Propane and may require the use of additional tanks and more frequent refilling of the tanks to supply enough propane to maximize heater output.
- Do not use the TES unit if outdoor temperature may drop close to or below -30°F. TES Thermal Fluid has a freezing point of approximately -30°F. If the heater shuts off, freezing of the fluid will cause severe damage to the TES unit, TEX Thermal Exchangers, hoses and fittings. Store your equipment indoors and protect from freezing.
- Do not place the TES unit in a location that would subject it to runoff from adjacent buildings.
- The combustion of propane produces carbon dioxide, carbon monoxide and oxides of nitrogen. An adequate supply of combustion air and sufficient ventilation is required to prevent these compounds from accumulating in toxic concentrations. Carbon monoxide is a colorless and odorless gas. If you are exposed to carbon monoxide, you may experience any or all of these symptoms:
  - Headaches, tightness across the forehead and temples.
  - Weariness, weakness, dizziness and vomiting.
  - Loss of muscular control. Watering and smarting of the eyes.

If any of these symptoms should develop, get into fresh air immediately, see your doctor for treatment and have your heater checked and repaired as needed.

- If the TES unit is to be installed for use in a closed trailer. It must have an exhaust stack installed to vent the burner exhaust through the roof of the trailer. There must be sufficient ventilation to exhaust the heat and supply adequate combustion air to the burner. Ambient air temperature above 130°F inside the trailer may adversely affect the operation of the pump and heater. A power vent fan should be used to bring in cooler air. Power exhaust vents should not be used. Fan should have at least 400 cfm of air movement to provide adequate cooling for operation during hot weather. Locate fan within 12” but not less than 3” from the floor of the trailer.
- A 7” diameter exhaust stack with vent cap is required. A “J” cap or other wind resistant vent cap should be used. Never install an exhaust pipe of a diameter different than that of the heater draft hood. 6” of clearance is required between the exhaust stack and any combustible materials. Use the shortest, straightest exhaust system possible.
- Two roof vents must be installed to exhaust the heat from the trailer and allow proper flow of combustion air. The roof vents must have a total minimum free area of 100sq. in. When calculating the vent area, consideration must be given to the blockage effects of louvers, grills and screens. The installation of two roof vents should easily provide sufficient vent air space when allowing for blockage. **Power vents should not be used. The heater should not be subjected to negative air pressure.** Negative air pressure can affect the burner flame and exhaust flow.
- Openings for the combustion air supply must have a total minimum free area of 100 sq. in. When calculating the vent area, consideration must be given to the blockage effects of louvers, grills and screens. The openings must be within 12” but not less than 3” from the floor of the trailer. A power vent fan may be used to bring in air. The free air space of the hose access door can be used as part of the total vent space. The blockage of the hoses must be considered when calculating the free space of the hose access door. The hoses may reduce the total free area to a total less than the required 100 sq. in. and require the addition of a second vent.

***This heater is an electrical appliance. Care must be taken to reduce the risk of electrical shock.***

- **Use a Ground Fault Interrupting (GFI) device to reduce the risk of electrical shock.**
- Extension cords must be rated for outdoor use, grounded and able to deliver the proper current to the heater and pump. (10 amps)
- Do not use a multiple outlet power cord to connect to TES unit plug.
- Keep cord connections off the ground. Protect cord connections from rain or other water sources.
- Never operate this heater with a damaged power cord. If the power cord is damaged it must be replaced.
- Unplug machine power cord from outlet before connecting or disconnecting quick connects on TES unit.
- Unplug machine power cord from outlet before performing any repair on the TES heater or pump.
- To reduce the risk of property damage or injury, repairs to electrical systems should only be performed by experienced technicians. Contact your nearest service center for assistance.
- If solution lines, pump or heater are leaking, unplug machine power cord from outlet before approaching or touching machine.

***This heater operates with hot solution under pressure. TES Thermal fluid under pressure and at high temperature can cause burns, severe personal injury or death. The TES Thermal Energy System must be operated and maintained properly to reduce the risk of burns or other injuries.***

- Always turn Pump ON before turning Heater ON.
- Turn Heater OFF, allow solution to cool, then turn Pump OFF and disconnect power cord before disconnecting any hose from the TES unit.
- Turn Heater OFF, allow solution to cool and turn Pump OFF before disconnecting any hose from the thermal exchangers, solution tees or other hoses.
- Wear eye protection when connecting and disconnecting hoses.
- With pump OFF, hoses and fittings will retain 12 psi system pressure. Quick connects may stick open and leak. Press nipple on quick connect to release fluid and flush debris and allow the quick connect to re-seal.
- Wrap a towel around quick connects when disconnecting hoses to catch released fluid.
- Do not operate this heater unless all panels are in place and properly secured.
- Keep hose access door on TES unit closed and locked during operation. Do not leave key in lock.
- Keep control panel door on TES unit closed and locked during operation. Do not leave key in lock.
- Keep cover on TES fluid reservoir during operation.
- Add TES Thermal Fluid to reservoir as needed to maintain an adequate fluid supply to pump and heater.
- Hot brass fittings can damage some carpets or cause burns. Wrap and insulate quick connects and solution tees to prevent damage or burning.
- Hoses must be rated to handle 230°F fluid temperatures, 5/8" or 3/4" ID for adequate flow and insulated to hold heat and protect from burns.
- Do not use water in heater, hoses or heat exchangers. Use only TES Thermal Fluid. Failure to do so may result in damage to heater and will void warranty.
- Do not by-pass Flow Switch. A continuous adequate flow of solution through heater must be maintained. Failure to do so may result in damage to heater and will void warranty.
- Never try to repair the pressure relief valve. If the valve fails to operate properly, replace the valve. Removal or restriction of the pressure relief valve could damage heater, cause severe personal injury or death.
- If solution lines, pump or heater are leaking, unplug machine power cord from outlet before approaching machine.

## Warranty

Your TES Thermal Energy System is designed to give you years of reliable service. If a problem should arise use the troubleshooting section in the operation manual to diagnose and correct the problem if possible. If you are unable to determine the cause or solution to the problem contact your distributor or Bridgepoint Systems for assistance.

Bridgepoint Systems warrants the heat exchanger inside the TES unit to be free from defects in material or workmanship for five years from the date of purchase.

Bridgepoint Systems warrants the roto-molded body of the TEX Thermal Exchanger to be free from defects in material or workmanship for five years from the date of purchase.

All other components of the TES Thermal Energy System are warranted to be free of defects in material and workmanship for one year from the date of purchase.

During the warranty period, Bridgepoint Systems will, at its option repair or replace components which prove to be defective.

- This warranty does not provide for replacement of complete units due to defective components.
- Service Labor is only covered for the first 90 days after the date of purchase.
- Any costs for transportation are not covered in this warranty.
- Replacement parts are warranted only for the remainder of the original warranty period.

This warranty **shall not** apply to defects resulting from improper operation, lack of maintenance, hard water deposits, condensation, chemical corrosion, unauthorized modification, misuse, abuse or exposure to freezing temperature conditions without proper propylene glycol & water solution.

This warranty **does not** cover normal wear items such as o-rings, valve seals, pump seals, hoses, quick connects, cords, tires, burner jets, or other items which require replacement as a result of ordinary usage.

To obtain warranty service for the TES Thermal Energy System, contact your distributor or Bridgepoint Systems. If the unit must be returned to Bridgepoint Systems or an authorized service center, the purchaser shall prepay shipping charges for products returned for warranty service.

- No returned items will be accepted by Bridgepoint Systems without prior authorization. All returns must have a return authorization number, issued by Bridgepoint Systems, clearly marked on the exterior of the package.

Bridgepoint Systems makes no other warranty either expressed or implied with respect to this product. The remedies provided herein are the purchaser's sole and exclusive remedies.

In no event shall Bridgepoint Systems be liable for any direct, indirect, special, incidental or consequential damages.

This warranty gives you specific legal rights. You may also have other rights which vary from jurisdiction to jurisdiction.